

ASSEMBLY AND INSTRUCTION MANUAL

MODEL 0319 TAO

© 2019 KURT BEIER & KATI QUINGER



Focus Open 2020
Special Mention



Optionally Turnable up to 360°



Practical stool or armrest cushion



Optionally functional bracket
with practical back cushion

Assembly of type 23T:

ATTENTION! To ensure secure assembly, please observe the individual steps of instruction! It is necessary that the furniture always be mounted in pairs (2 persons)!

1. Place the enclosed parts in front of you.

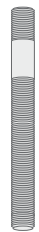

4 x grub screw (a)



4 x washer (b)



4 x nut (c)

2. Position the elements at the place supposed to stay and place the upholstery upside down on the floor. To avoid damages at the furniture or at the floor use a suitable support.

3. Screw in the enclosed grub screws (a) into the 4 threads (d).

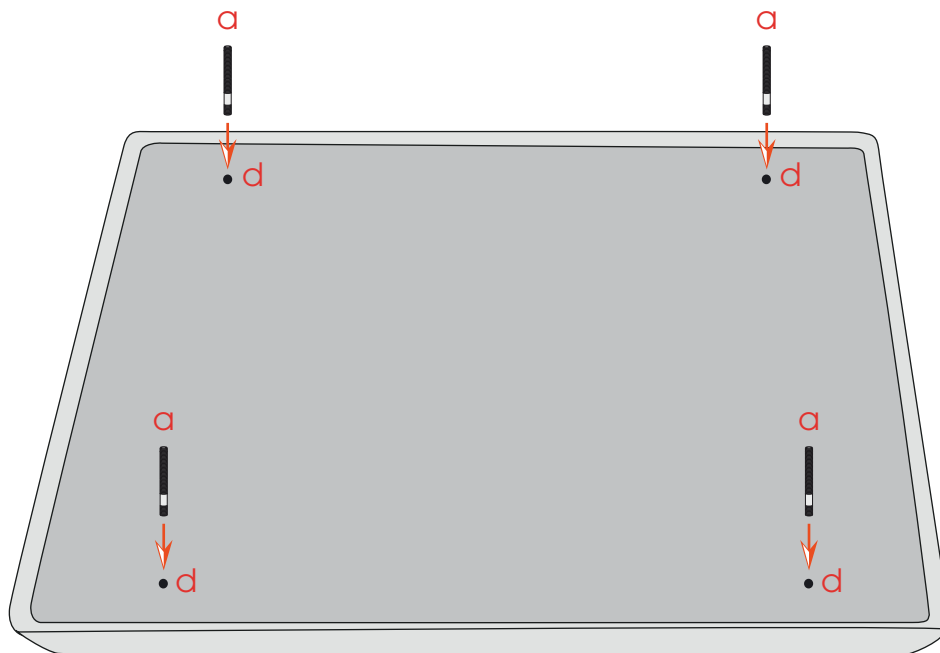

4. Apply the plateau with its 4 bores (e) onto the 4 grub screws (a).

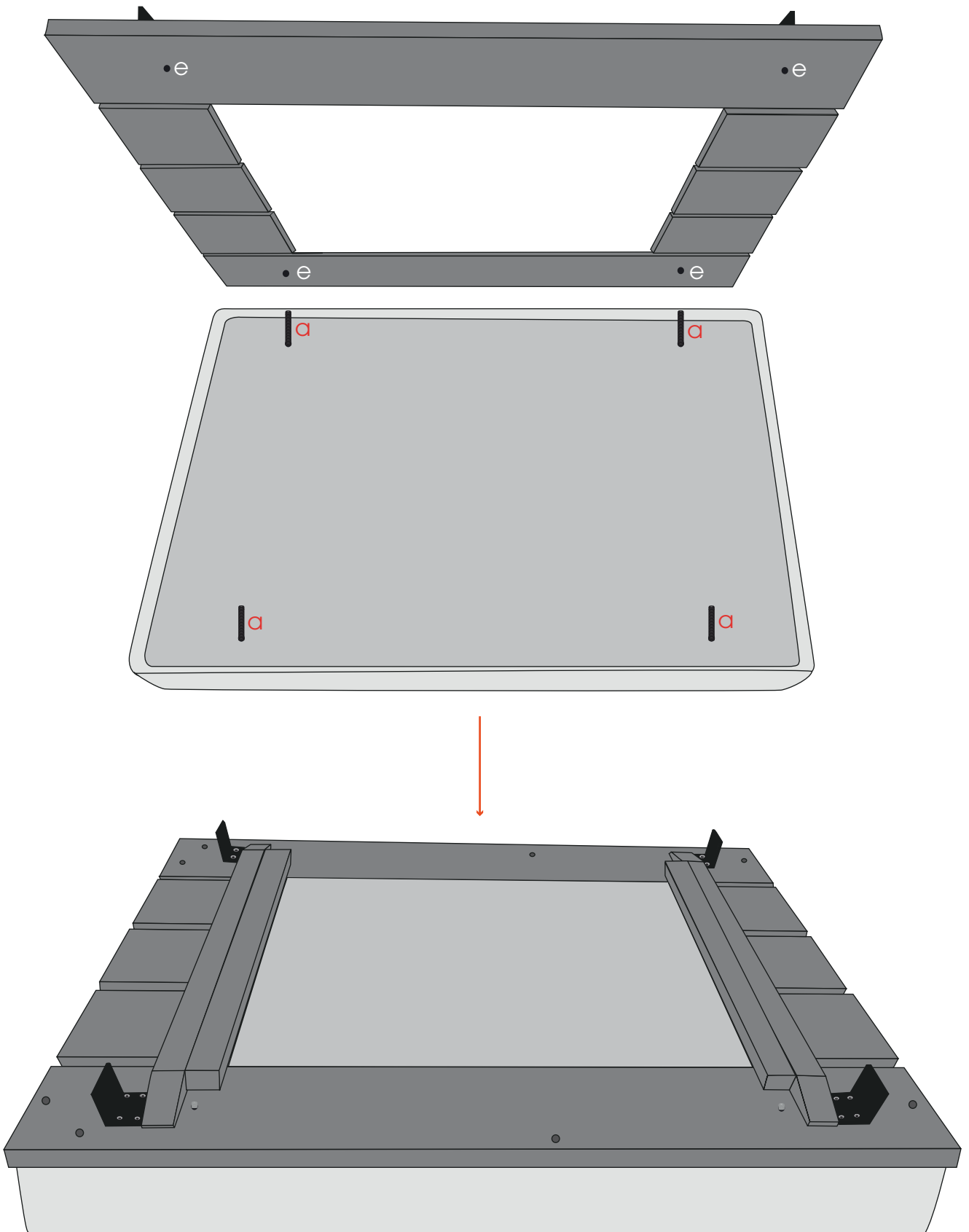

5. Plug washers (b) onto grub screws (a) and tighten them with a nut (c).

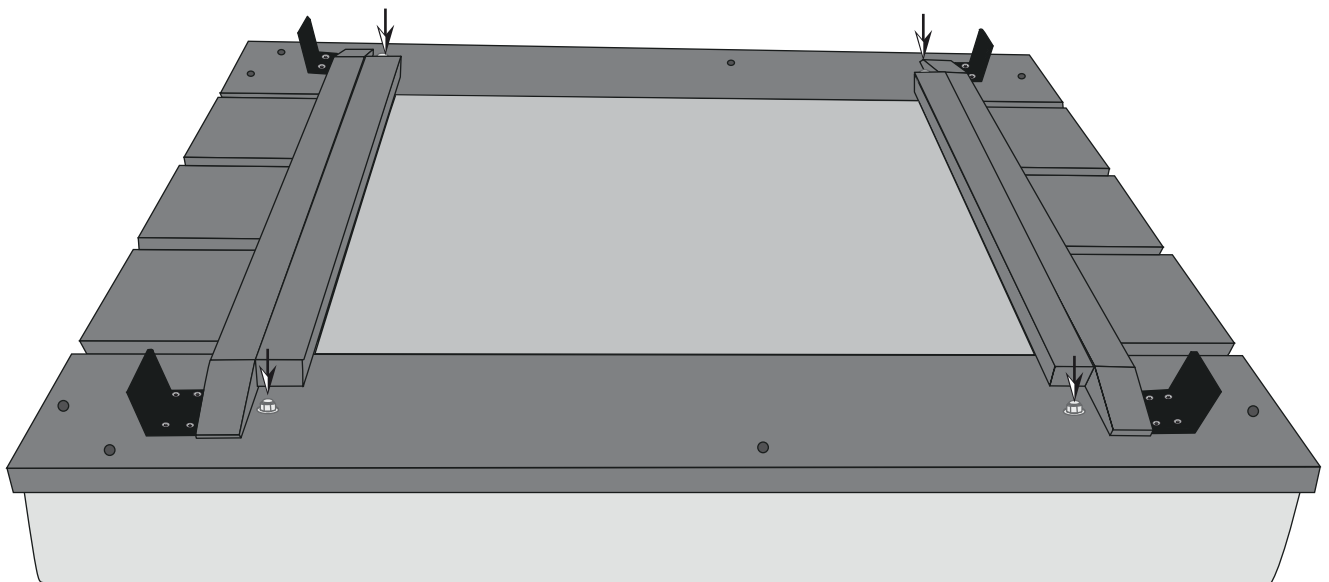
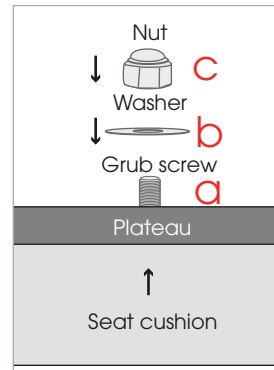

6. Mount the connectors! See: "mounting of connectors"!

7. Tilt mounted sofa forward onto its feet.

Assembly of type 23TF:

ATTENTION! To ensure secure assembly, please observe the individual steps of instruction!
It is necessary that the furniture always be mounted in pairs (2 persons)!

1. Unscrew bolt with enclosed allen key from cone and place bolt, large washer and small washer in front of you.



2. Position the elements at the place supposed to stay and place the upholstery upside down on the floor. To avoid damages at the furniture or at the floor use a suitable support.

3. Lift plateau above the seat cushion.

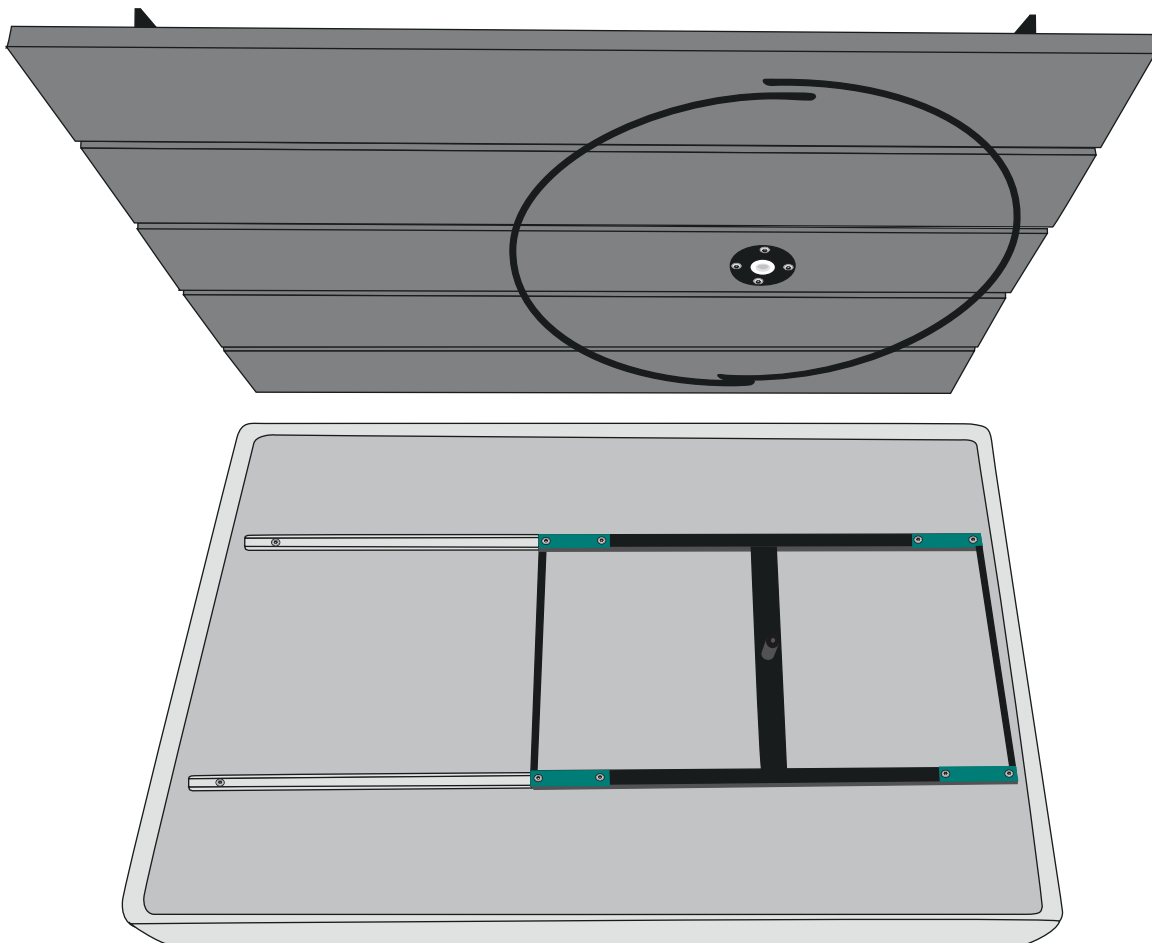

4. Position the bearing bush (a) of plateau above cone (b) of seat cushion.

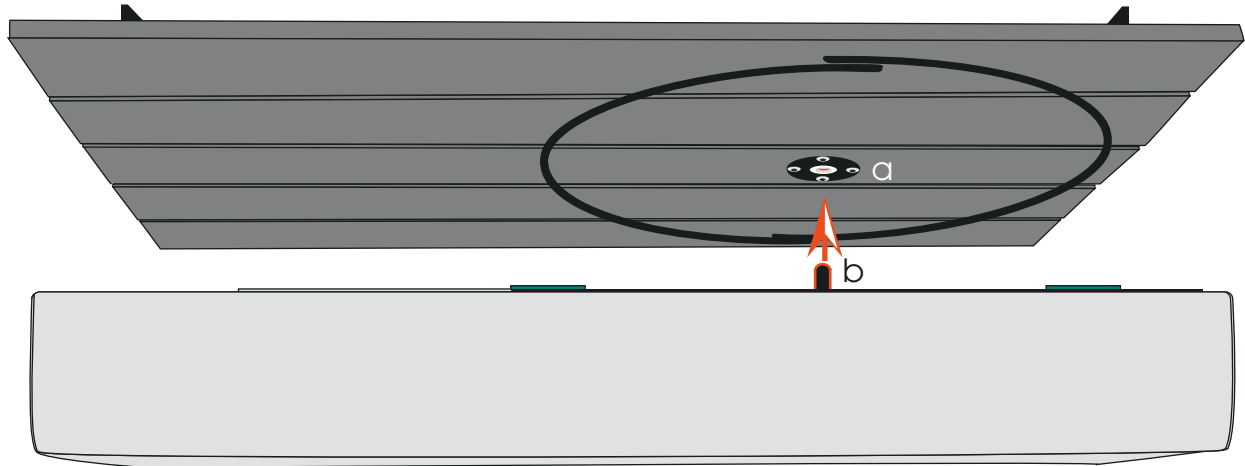

5. Plug bearing bush (a) of plateau onto cone (b) of seat cushion.

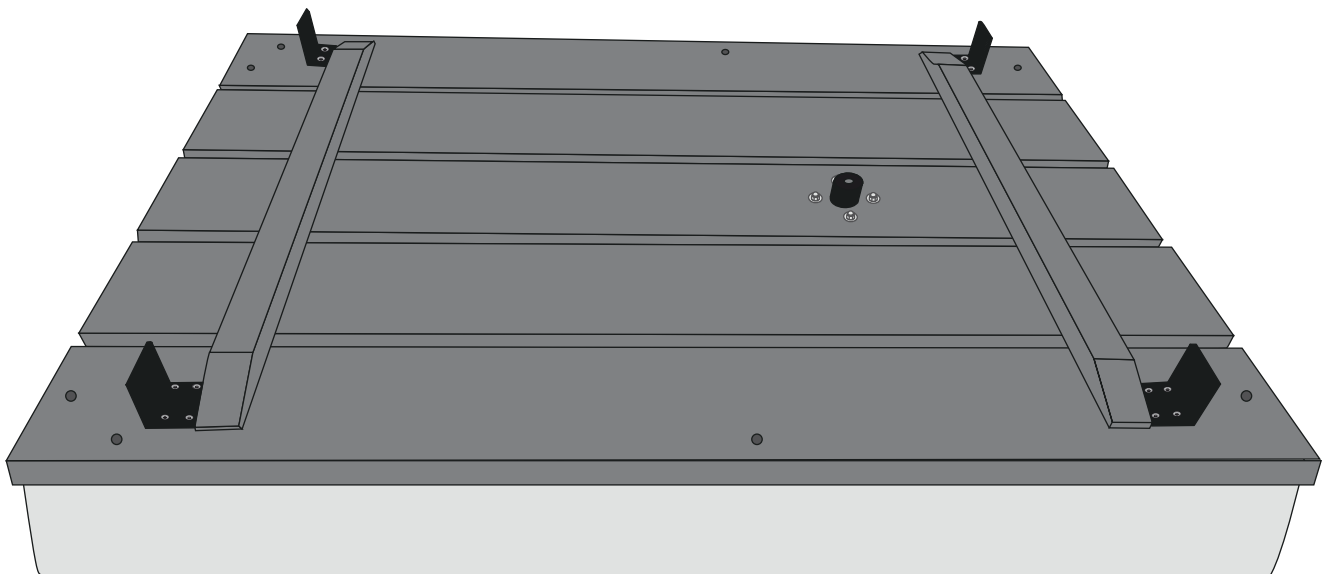

6.

- 1) Place the large washer onto cone.
- 2) Place the small washer on large washer and tighten it with enclosed screw. Turning heaviness is adjustable by contact pressure of screw.

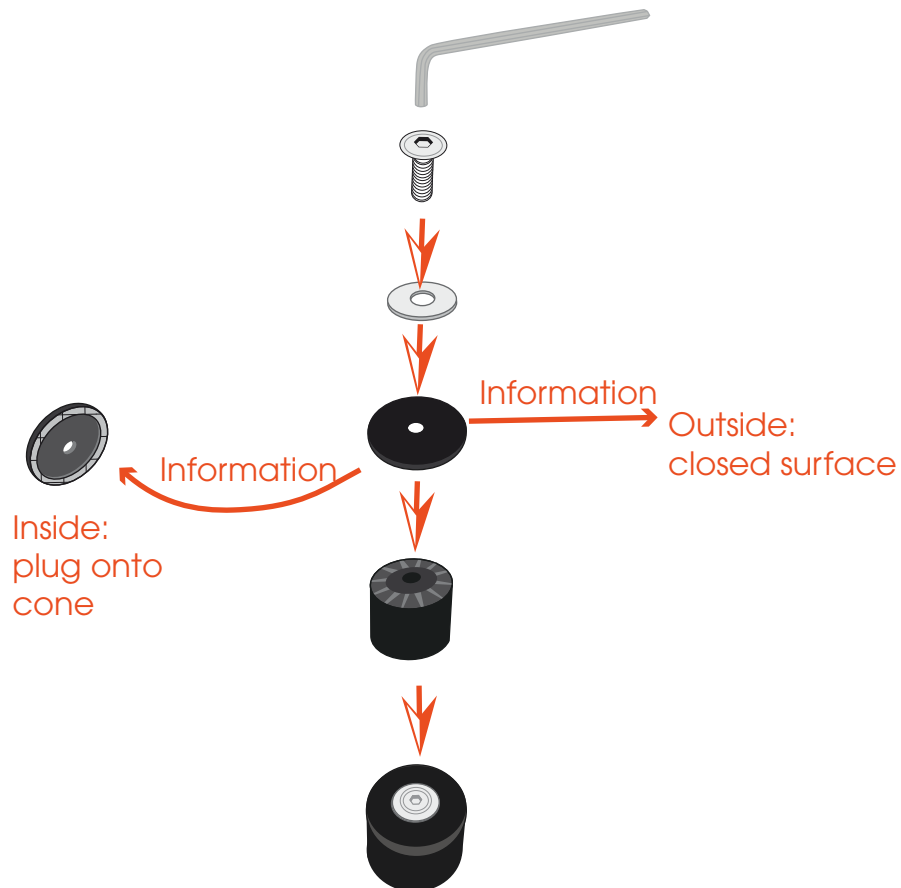

7. Mount the connectors! See: "mounting of connectors"!

8. After assembly of connectors: tilt mounted sofa forward onto its feet. Pay attention to plateau and seat cushion, it may move unintentional due to rotary and sliding system.

Mounting of connectors:

Possible connector points:

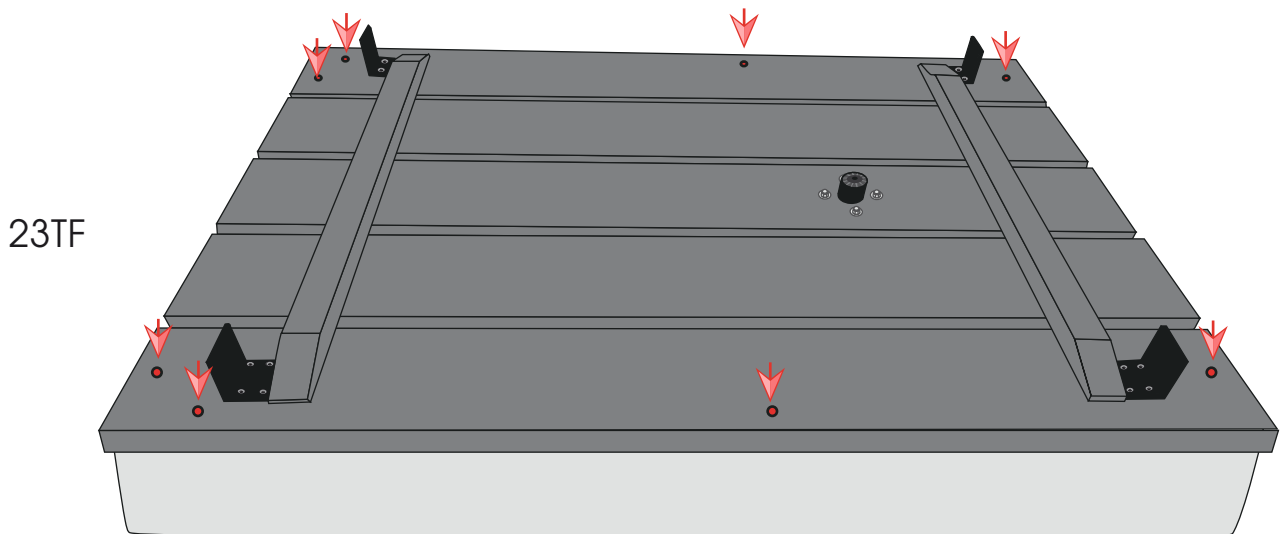
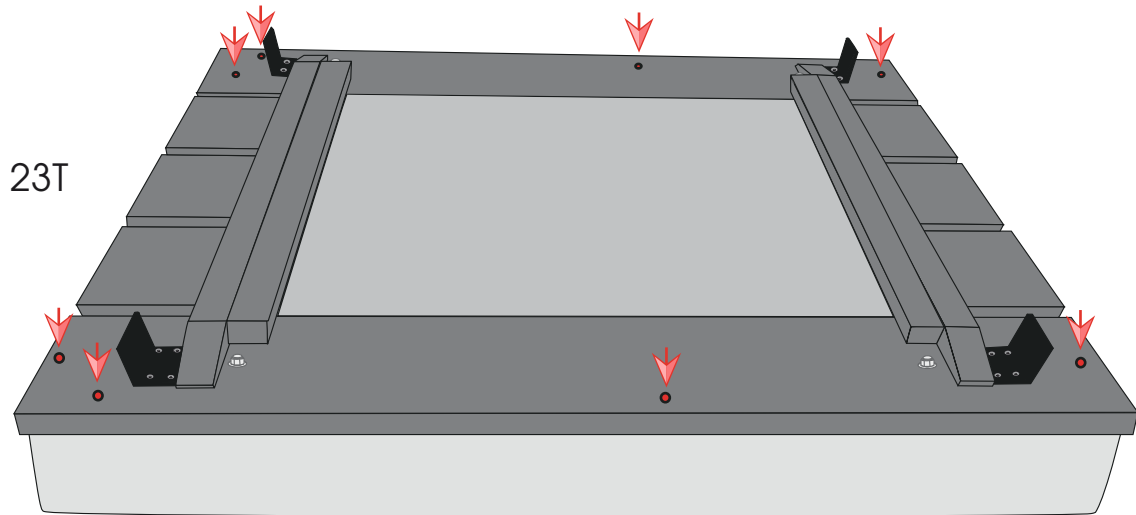

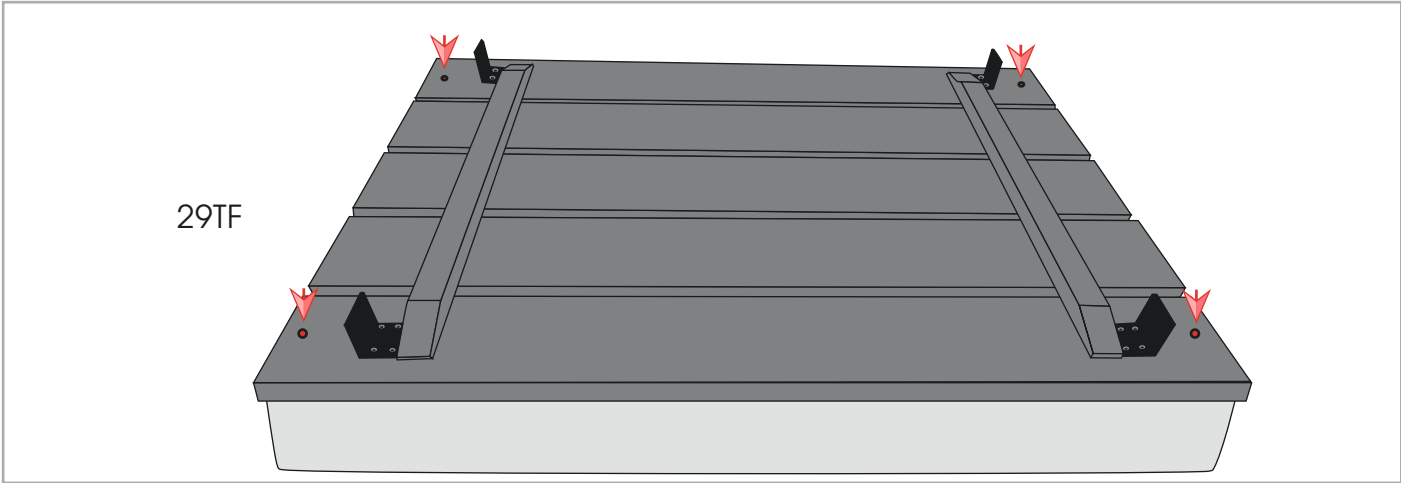

Mounting of connectors:

Place the enclosed parts in front of you.

Hand screw 2

1 Connector

1. Screw connectors (1) of element (A) with the hand screws (2) into threaded sockets and tighten hand screws (2).

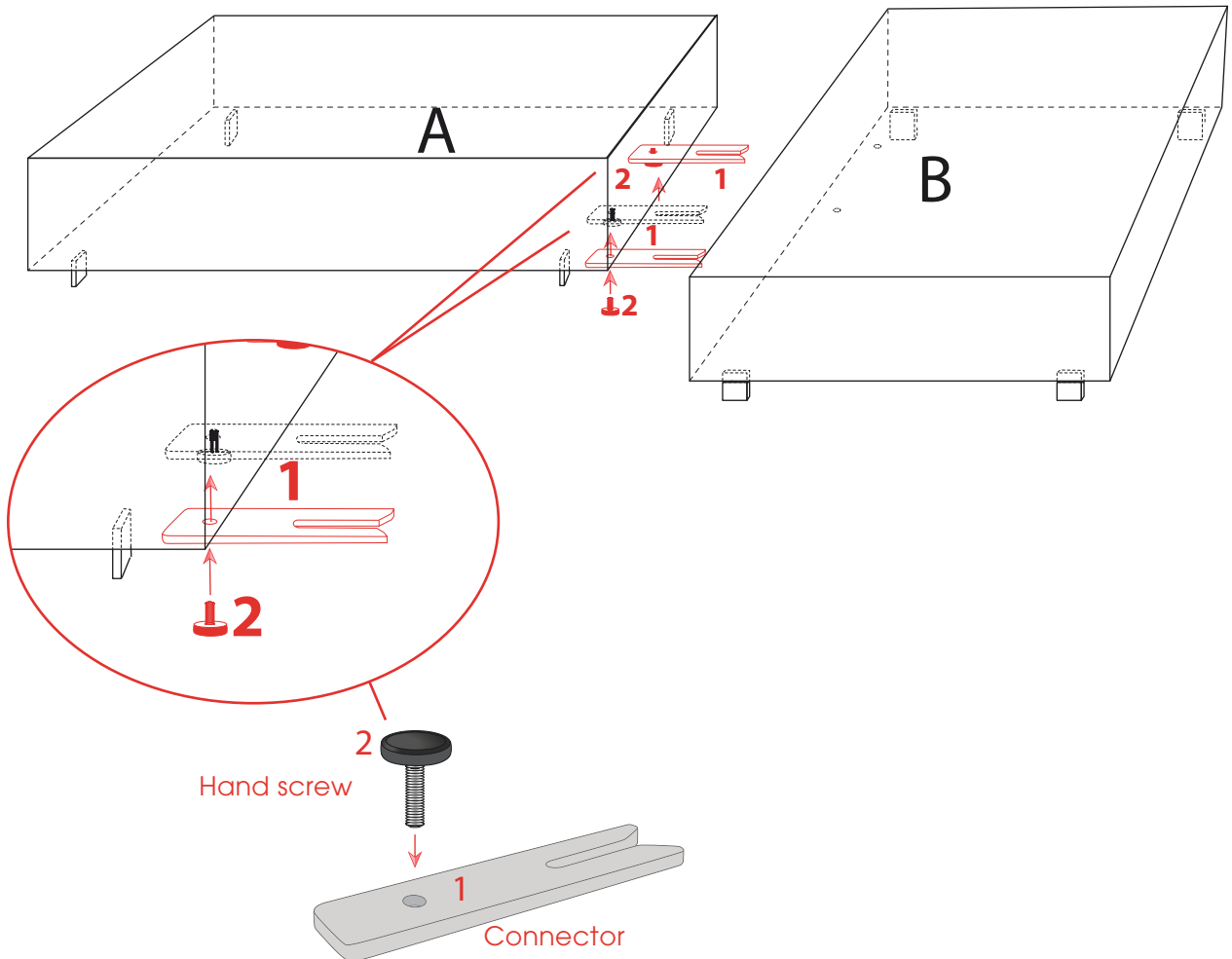

2. Screw hand screws (2) slightly into element (B), so that hand screws do not drop of.

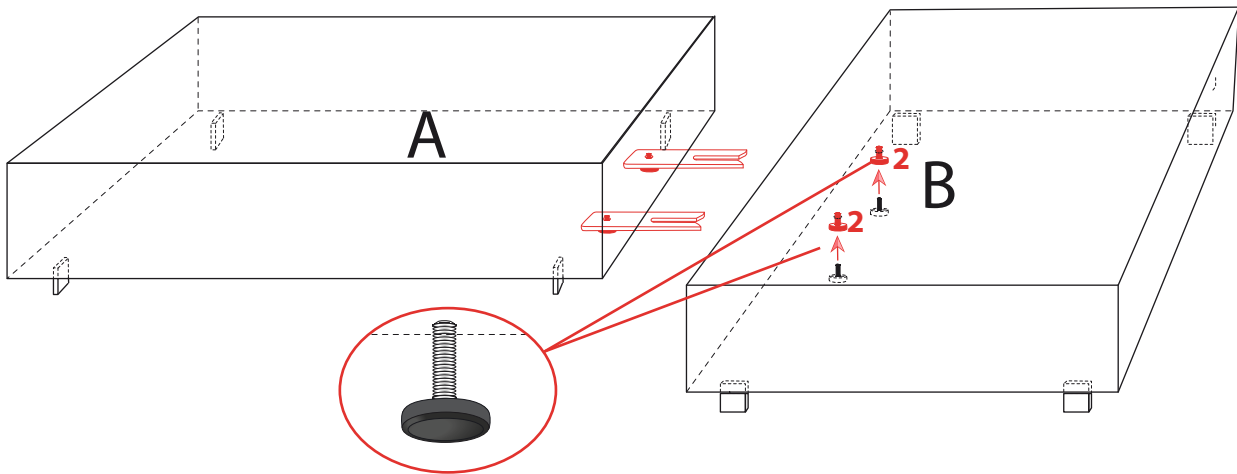

3. Firmly push together (A) and (B) so the threaded bar of hand screw (2) will slide into the slot of connector (1) of element (B).

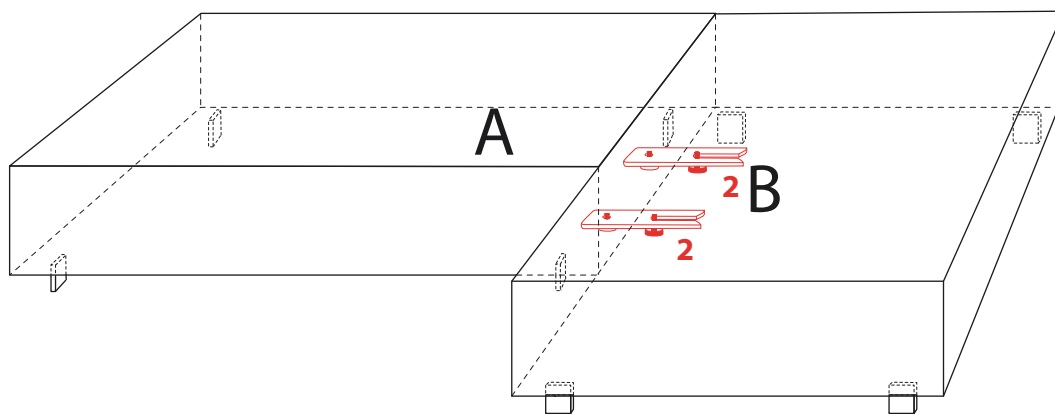
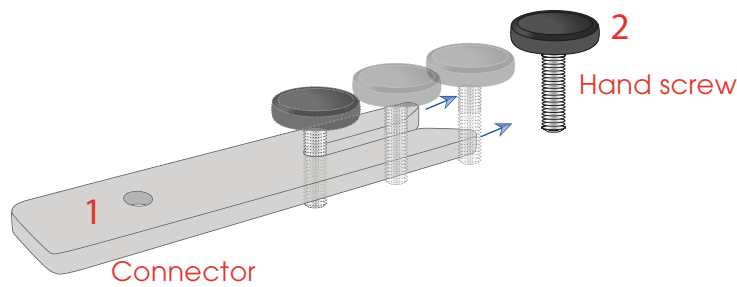

4. Tighten hand screws (2).

Use of functional bracket:

Adjustment of functional bracket:

1. Pull the functional bracket into desired position.

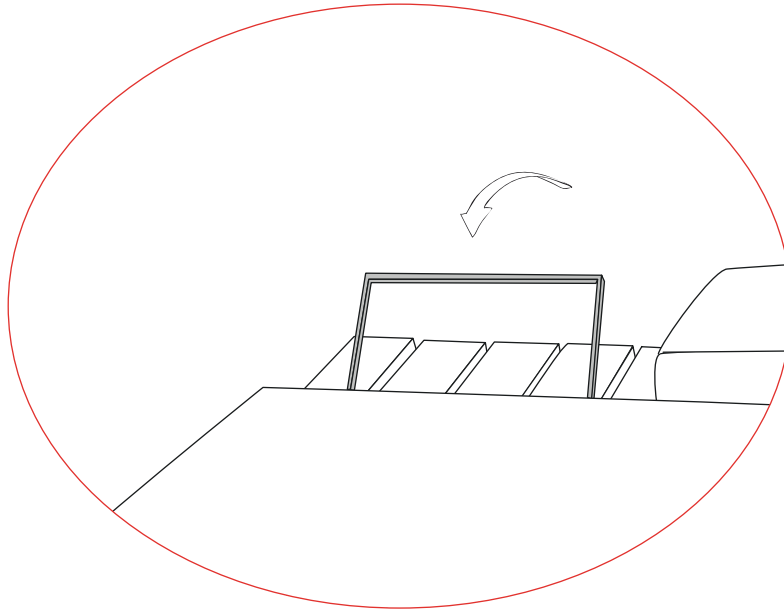

2. To obtain zero position pull the functional bracket carefully beyond the top position (a) and fold down into zero position (b).

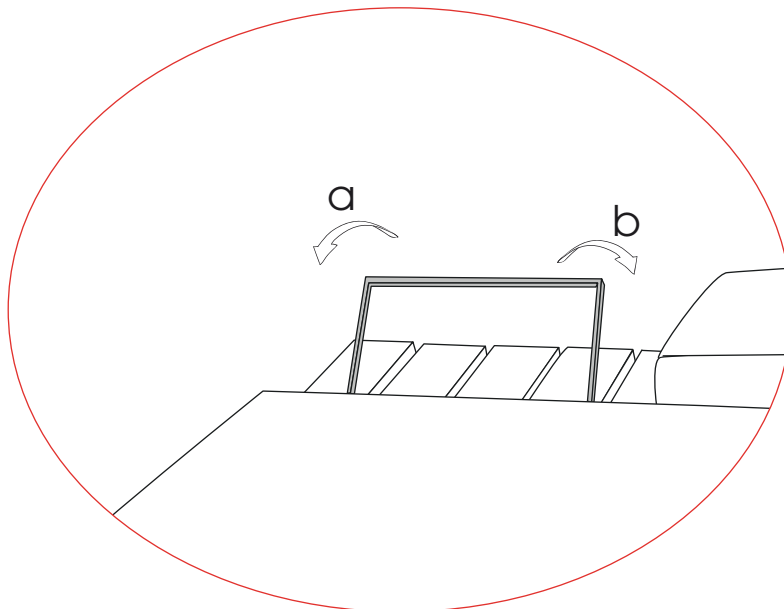

3. From zero position you can easily snap the armrest into desired position.

ATTENTION! DON'T SIT ON FUNCTIONAL BRACKET!

Attention! Functional bracket 606 is subsequently mountable with type 23TF.
Therefore needed parts can be ordered separately!

If necessary the functional bracket can be pulled out of the Plateau. Proceed as follows:

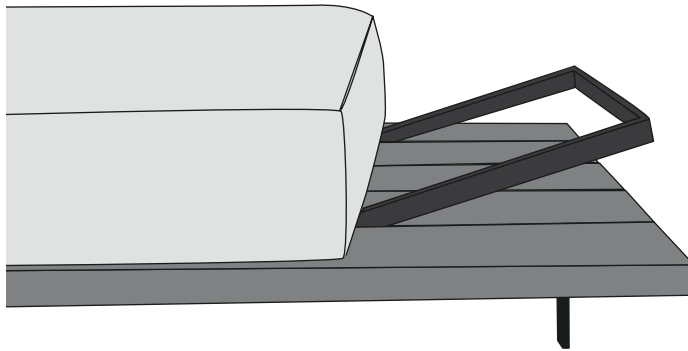

← 1. Slightly lift up functional bracket.

2. Grasp the bracket with both hands (a) and pull it with a powerful jolt horizontal (b) out of the plateau!

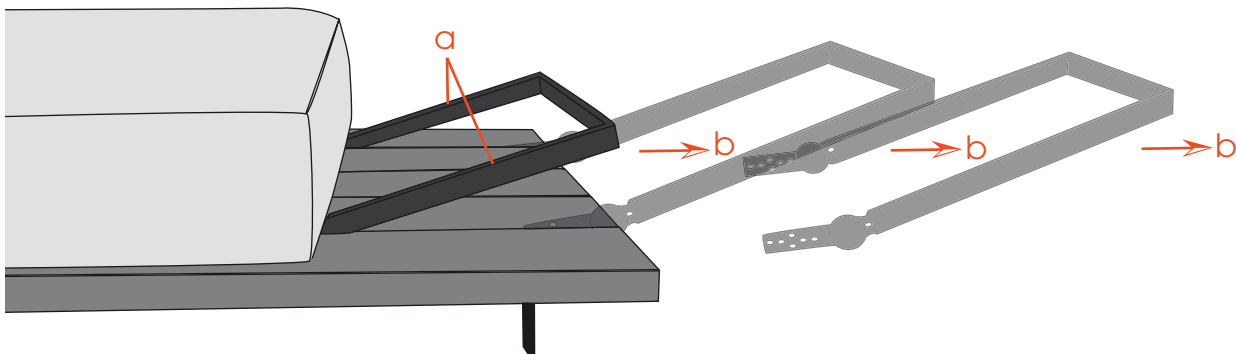

How to plug the bracket in again:

1. Put the functional fitting into a horizontal position (c).



2. Push the seat upholstery in a position so that the slots for functional fittings are visible.

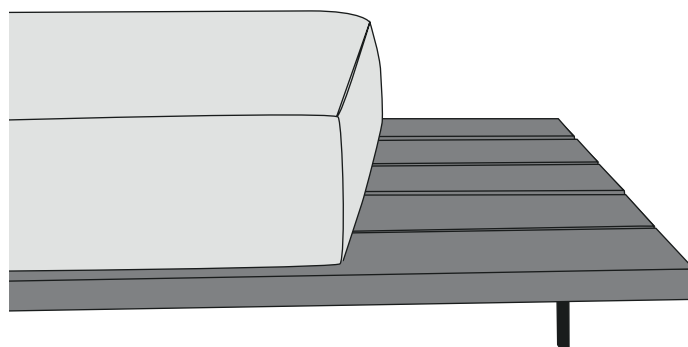

3. Position the functional fittings horizontal between the wooden planks.

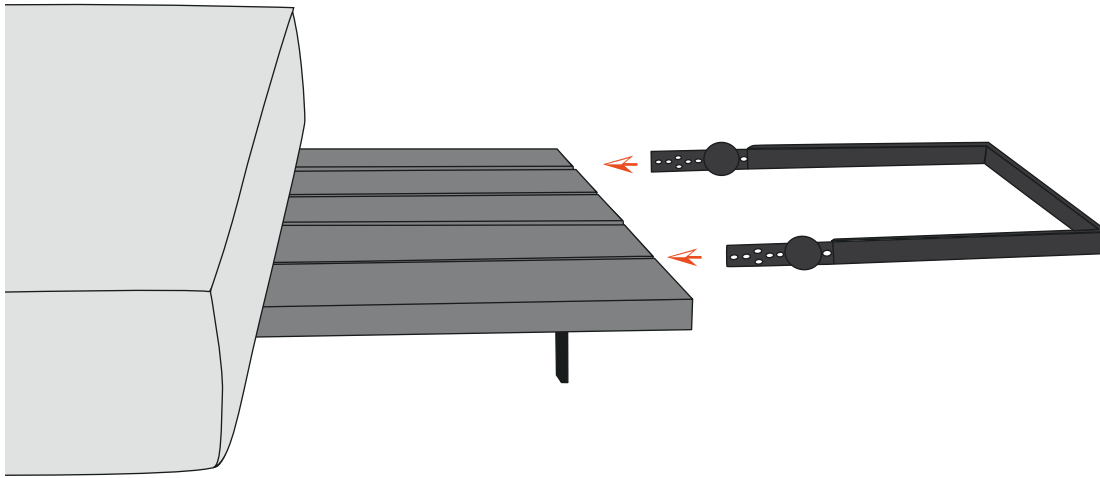

4. Place the functional fittings straight at the provided slots (d). Fasten it with a powerful jolt in forward direction.

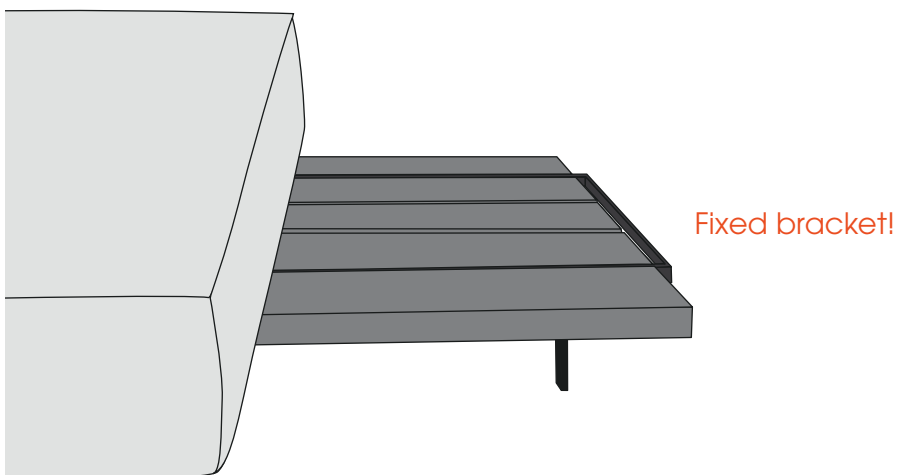
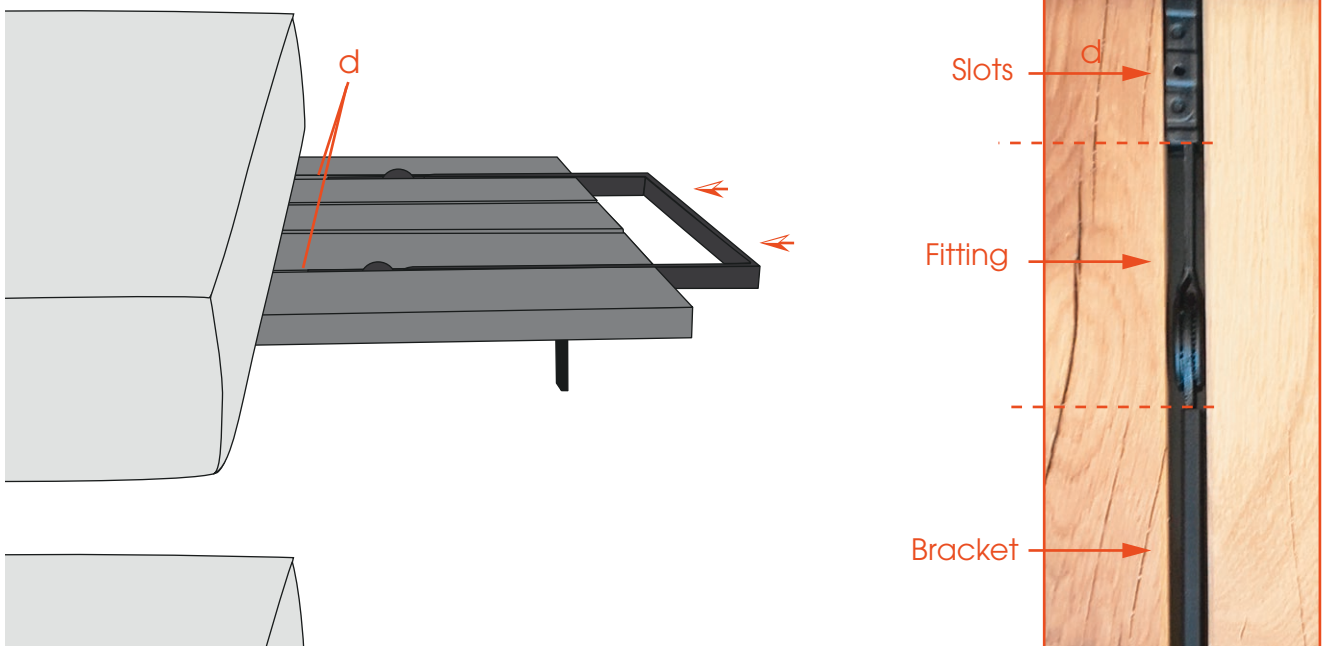

Use of back function

Adjustment of back slant:

1. To adjust the desired position grip the back from the outside and pull it carefully towards yourself.



2. To obtain zero position pull the back carefully beyond the top position towards yourself and fold down into zero position (horizontal).



3. From zero position you can easily snap the back into desired position.

