

ASSEMBLY AND INSTRUCTION MANUAL

MODEL 1044 BEO

© 2015 KURT BEIER & KATI QUINGER



Functional back and armrests are completely foldable



...up to a comfortable relax lounge



Due to lateral seat adjustment arises a useful clipboard

Use of back- and armrest function

1. Adjustment of back slant:

To adjust the desired position grip the back from the outside and pull it carefully into your direction.

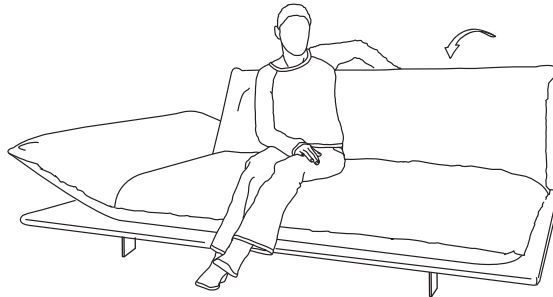

2. To obtain zero position pull the back carefully beyond the top position into your direction and fold down into zero position.

3. From zero position you can easily snap the back into desired position.

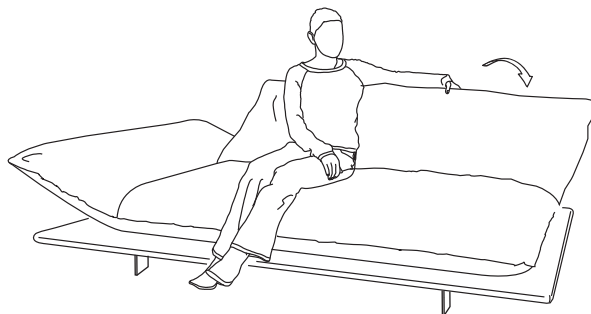

To adjust armrest, proceed the same way.

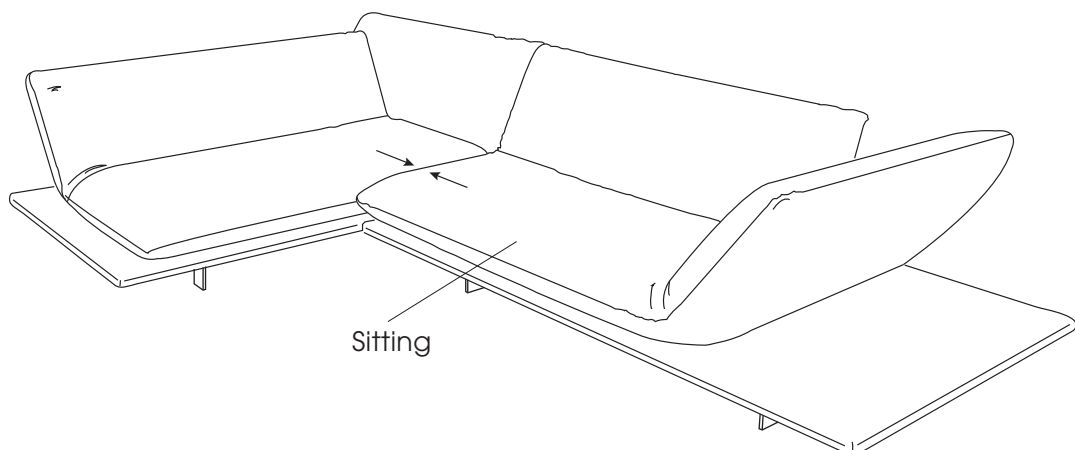

ATTENTION!
DON'T SIT DOWN ON BACK OR ARMREST EXCEPT THEY ARE AT LOWEST POSITION.

Motorised seat adjustment

1. Connect cable A (fixed at seat element) to provided transformer and plug it into socket.
2. Press button B and C at remote control to move seat continuously to the right or to the left.

At types with manual adjustment, the seat cushion can be moved manually back and forth in the direction of the arrow .

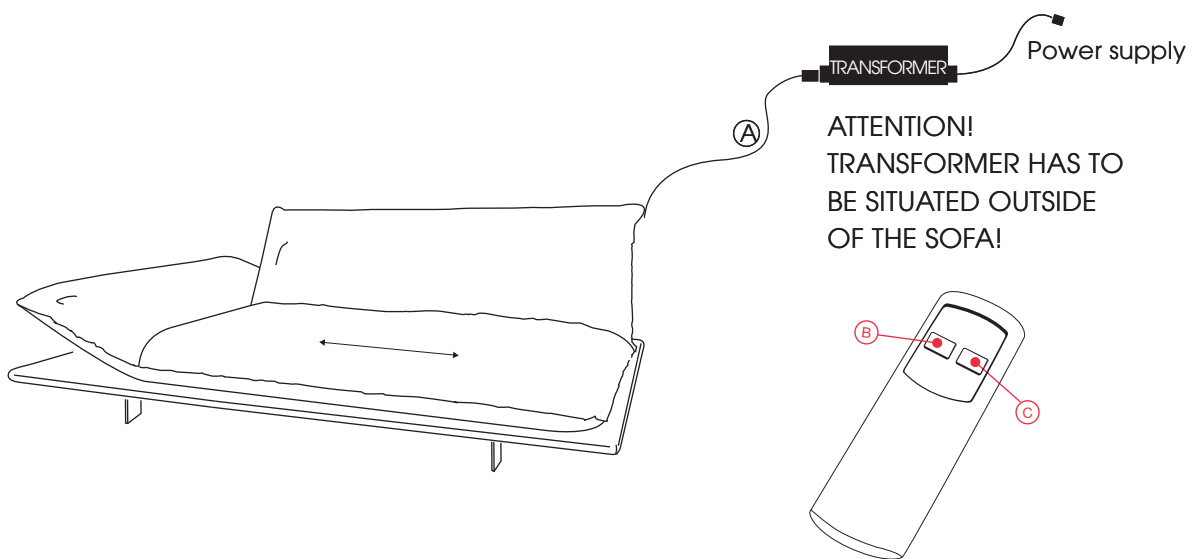

To avoid traces of usage at cover material, seat should (as possible) only be adjusted when back and armrest are folded up (like fig. above).

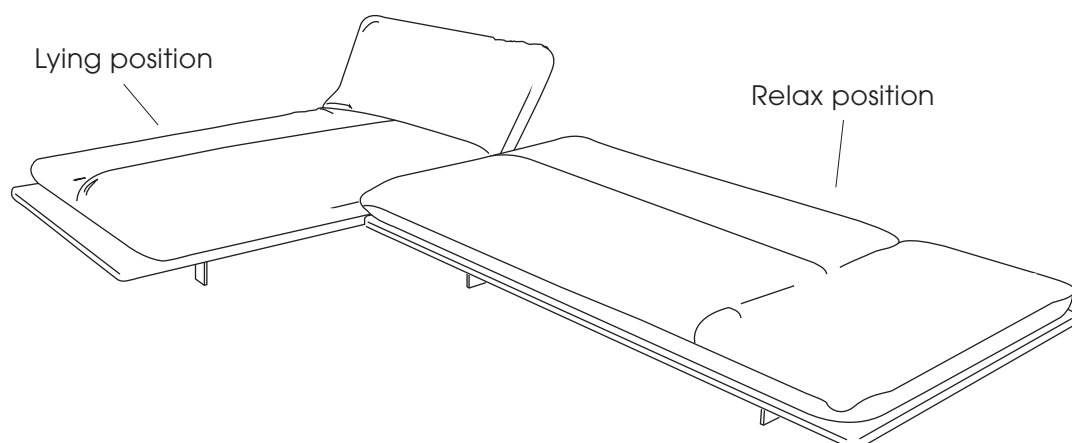

Motorised seat adjustment - Programming of transmitter and receiver

Delivery condition: already synchronised

November 2021

Brief instruction, Pairing-Method:

Should a new start-up of remote control be necessary the wireless communication with the control/motor must be established. Proceed as follows:



1. Press pairing buttons A at receiver 2 x until the LED indicates. The pairing process is active for about 10 seconds.

2. Press simultaneous button B and C at the transmitter until the green LED at the receiver vanishes. This confirms a successful pairing process.

Note: For the pairing process the distance between transmitter and receiver should be less than 2 metres.

The programming is completed, the transmitter is now ready for operation. If the motor doesn't start while pressing, release the button and press again. If necessary retry the process.

The programming is completed, the transmitter is now ready for operation. If the motor doesn't start while pressing, release the button and press again. If necessary retry the process.



Put drive systems into operation successively, **don't** operate several systems simultaneous. Otherwise the remote control cannot be assigned clearly by control/motor.

FUNKI - how it works:

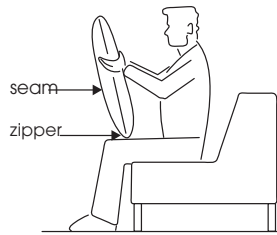

1. Take the cushion at its upper side and put the cushion on your knees with the zipper on the bottom. The seamless side faces you.

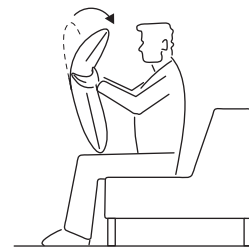

2. Move the upper part of the cushion towards yourself until the final position is reached.

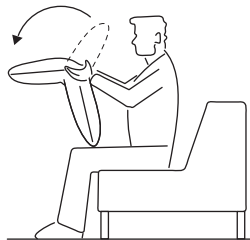

3. Now you are able to move the upper part backwards until the upper part of the cushion will click into place in the zero position.

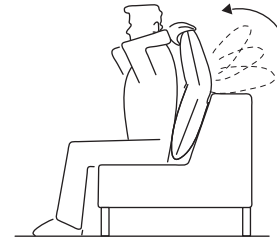

4. Now put the cushion in the preferred position (e.g. in the back, seamless side in front and zipper at the bottom). By pulling the upper part of the cushion towards yourself, you are now able to choose among 16 raster positions, however you like it.

Mounting of connectors

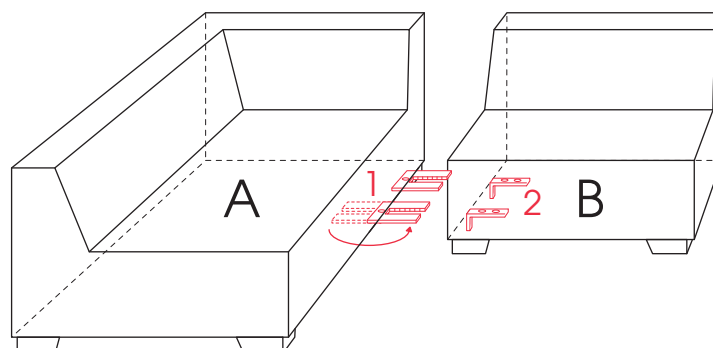

1. Turn connector ratchet 1 of element A to the outside.
2. Firmly push together part A and B, until metal guides 2 catch into guides 1.
3. In case of dismounting lift part B with the metal guides 2 and pull away.